

TYPE: AAS1537

ANSI Absperrschieber 2" – 24" Class300

ANSI Gate Valve 2" – 24" Class300

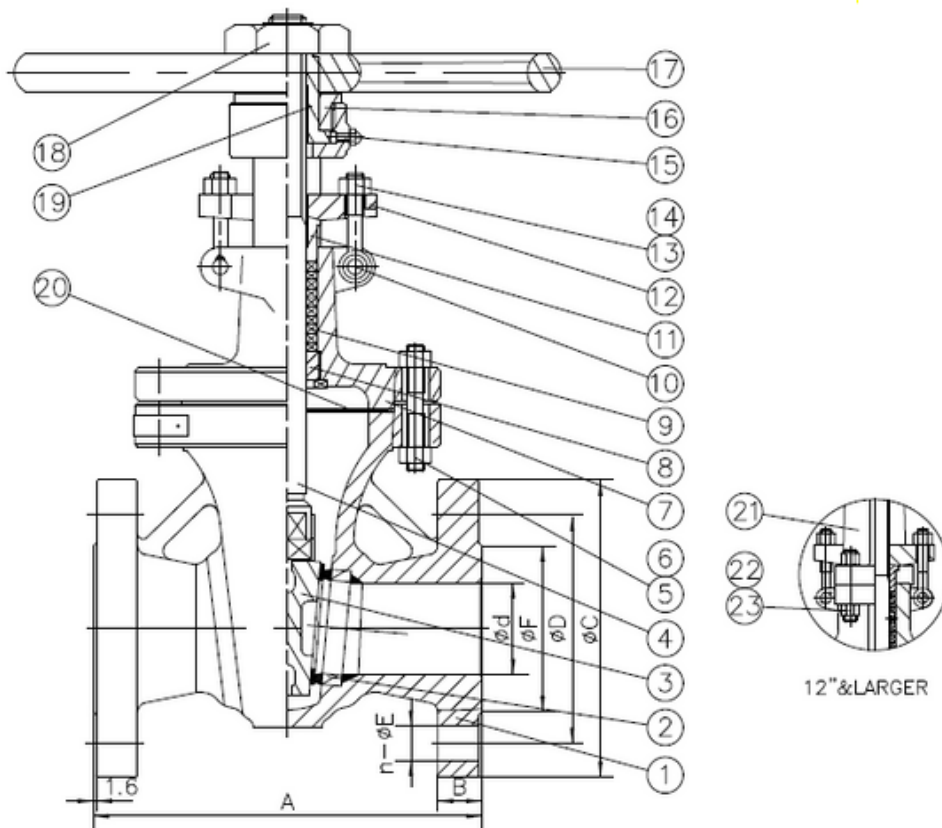

Technical Specification:

1. Design and machining acc. API600
2. Inspection and test acc. API598
3. Face to Face acc. B16.10
4. Dimension of connection end flange acc. B16.5 (RF)

DRW Industrietechnik GmbH

Bodenschwinger Str. 125

D-44357 Dortmund

Telefon: +49 2 31 - 92 71 44-0

info@drw-armaturen.de

www.drw-armaturen.de



Abmessungen / Dimensions:

SIZE	d	A	B	C	D	n	E	F
2"	50.8	216	23	165	127	8	19	92
2.5"	63.5	241	26	190	149	8	22	105
3"	76.2	283	29	210	168.5	8	22	127
4"	101.6	305	32	254	200	8	22	157
6"	152.4	403	37	318	270	12	22	216
8"	203.2	419	42	381	330	12	25	270
10"	254	457	48	445	387.5	16	29	324
12"	304.8	502	51	520	451	16	32	381
14"	336.6	762	54	584	514.5	20	35	413
16"	387.4	838	58	648	571.5	20	35	470
18"	431.8	914	61	711	628.5	24	35	533
20"	482.6	991	64	775	686	24	35	584
24"	584.2	1143	70	914	813	24	41	692

Materialien / Materials:

No.	Part Name	Material
1	Body	ASTM A351-CF8M+STL
2	Gate	ASTM A351-CF8M
3	Steam	ASTM A182-F316
4	Body/Bonnet Bolts	ASTM A193-B8
5	Body/ Bonnet Nuts	ASTM A194-8
6	Bonnet	ASTM A351-CF8M
7	Packing	Graphite
8	Pin	ASTM A276-410
9	Packing Gland	ASTM A276-316
10	Gland Flange	ASTM A351-CF8M
11	Packing Bolts	ASTM A193-B8
12	Packing Nuts	ASTM A194-8
13	StemNut Grease Injec.	ASTM A570 Gr.A
14	Gland Nut	ASTM A276-410
15	Hand Wheel	Nodular Cast Iron
16	Hand Wheel Nut	ASTM A276-410
17	Stem Nut	ASTM A439 D-2
18	Bonnet Gasket	SS316+Graphite
19	Yoke	ASTM A351-CF8M
20	Bonnet/Yoke Bolts	ASTM A193-B8
21	Bonnet/Yoke Nuts	ASTM A194-8

DRW Industrietechnik GmbH

Bodenschwinger Str. 125

D-44357 Dortmund

Telefon: +49 2 31 - 92 71 44-0

info@drw-armaturen.de

www.drw-armaturen.de

