

TYPE: AKS1438

ANSI Kleinschieber 0,5" – 2" Class150

ANSI Gate Valve 0,5" – 2" Class150

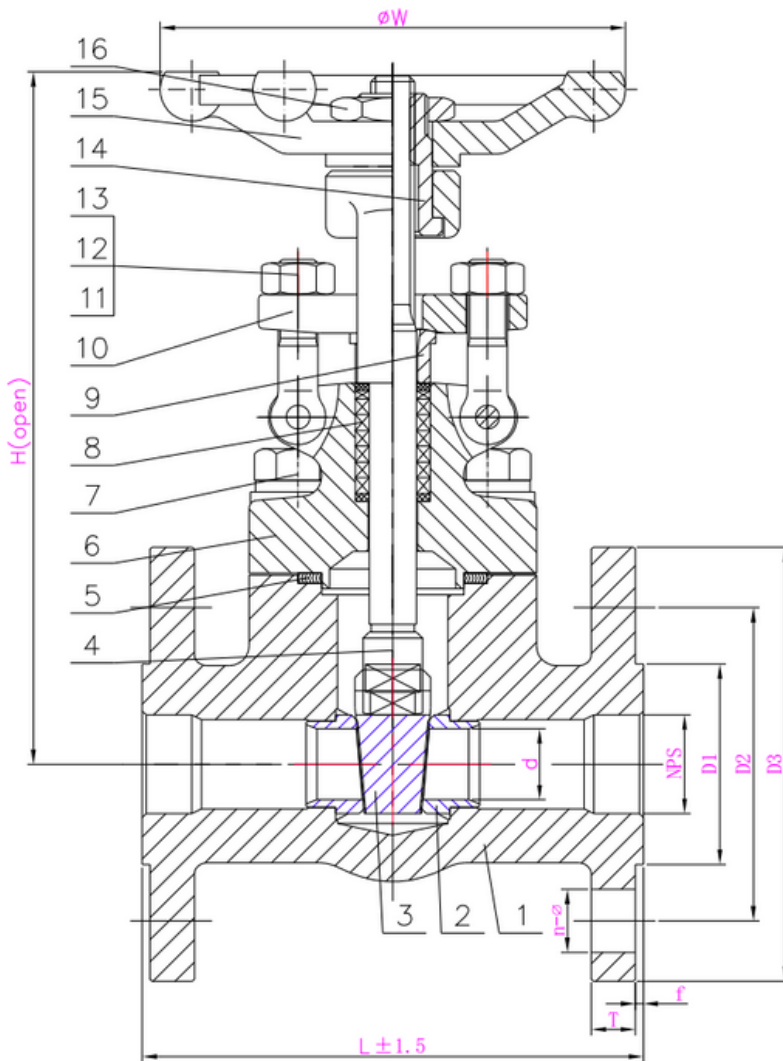

Technical Specification:

1. Design and machining acc. API602
2. Inspection and test acc. API598
3. Face to Face acc. B16.10
4. Dimension of connection end flange acc. B16.5

DRW Industrietechnik GmbH

Bodenschwinger Str. 125

D-44357 Dortmund

Telefon: +49 2 31 - 92 71 44-0

info@drw-armaturen.de

www.drw-armaturen.de



Abmessungen / Dimensions:

SIZE	L	W	H (open)	d	D1	D2	D3	T	f	n-ø
1/2"	108	100	152	10.0	34.9	60.3	90	9.6	2	4-16
3/4"	117	100	155	13.5	42.9	69.9	100	11.2	2	4-16
1"	127	125	186	18.0	50.8	79.4	110	12.7	2	4-16
1-1/4"	140	160	212	23.0	63.5	88.9	115	14.3	2	4-16
1-1/2"	165	160	236	28.5	73.0	98.4	125	15.9	2	4-16
2"	178	180	269	36.0	92.1	120.7	150	17.5	2	4-19

Materialien / Materials:

No.	Part Name	Material
1	Body	LF2
2	Seat	F304
3	Disc	F304
4	Stem	F304
5	Gasket	SS304 + Graphite
6	Bonnet	LF2
7	Bolt	L7
8	Packing	Graphite
9	Gland	F304
10	Gland Flange	LF2
11	Bolt	L7
12	Nut	7
13	Pin	1025
14	Stem Nut	1Cr13
15	Hand Wheel	A197
16	H.W Lock Nut	Carbon Steel

DRW Industrietechnik GmbH

Bodenschwinger Str. 125

D-44357 Dortmund

Telefon: +49 2 31 - 92 71 44-0

info@drw-armaturen.de

www.drw-armaturen.de

