

TYPE: ARK1421

Rückschlagklappe 2"- 24" Class150
Swing Check Valve 2"- 24" Class150

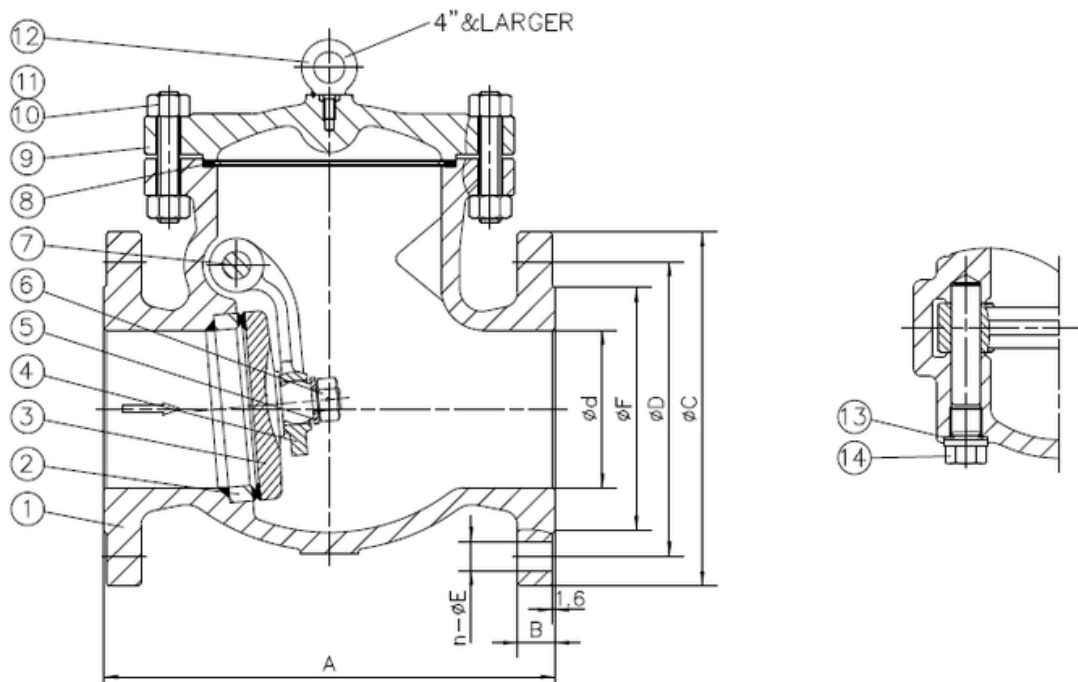

Technical Specification:

1. Design and machining BS 1868
2. Inspection and test acc. API 598
3. Face to Face acc. ASME B16.10
4. Dimension of connection end flange acc. ASME B16.5

DRW Industrietechnik GmbH

Bodenschwinger Str. 125
D-44357 Dortmund
Telefon: +49 2 31 - 92 71 44-0
info@drw-armaturen.de
www.drw-armaturen.de



Abmessungen / Dimensions:

SIZE	d	A	B	C	D	n	E	F
2"	50.8	203	16	150	120.5	4	19	92
2.5"	63.5	216	17.5	178	139.5	4	19	105
3"	76.2	241	19	190	152.5	4	19	127
4"	101.6	292	24	230	190.5	8	19	157
6"	152.4	356	26	280	241.5	8	22	216
8"	203.2	495	29	345	298.5	8	22	216
10"	254	622	31	405	362	12	25	324
12"	304.8	698	32	485	432	12	25	381
14"	336.6	787	35	535	476	12	29	413
16"	387.4	864	37	595	540	16	29	470
18"	438.2	978	40	635	578	16	32	533
20"	489	978	43	700	635	20	32	584
24"	590.6	1295	48	815	749.5	20	35	692

Materialien / Materials:

No.	Part Name	Material
1	Body	ASTM A216-WCB
2	Seat Ring	ASTM A105+STL
3	Disc	ASTM A105+Cr13
4	Arm	ASTM A216-WCB
5	Disc Washer	ASTM A276-410
6	Disc Nut	ASTM A276-410
7	Hinge Pin	ASTM A182-F6a
8	Cover Gasket	SS304+Graphite
9	Cover	ASTM A216-WCB
10	Cover Studs	ASTM A193-B7
11	Cover Nuts	ASTM A194-2H
12	Eye Bolt	ASTM A29-1035
13	Plug Gasket	SS304+Graphite
14	Plug	ASTM A29-1035

DRW Industrietechnik GmbH

Bodenschwinger Str. 125

D-44357 Dortmund

Telefon: +49 2 31 - 92 71 44-0

info@drw-armaturen.de

www.drw-armaturen.de

