

## TYPE: ARK1535

Rückschlagklappe 2"- 24" Class300  
Swing Check Valve 2"- 24" Class300

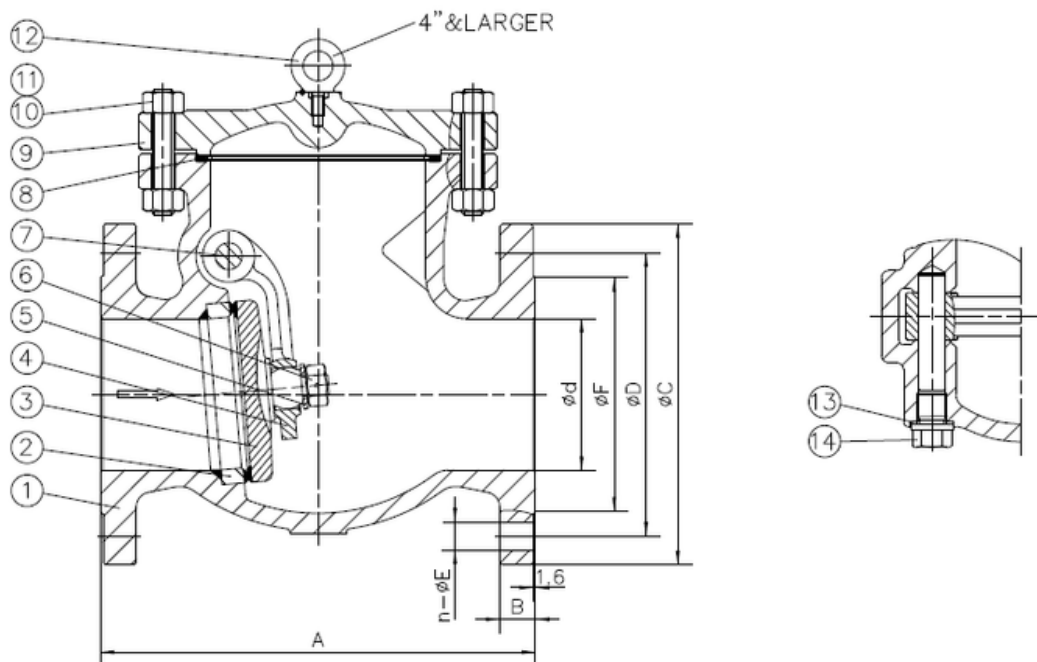

### Technical Specification:

1. Design and machining BS 1868
2. Inspection and test acc. API 598
3. Face to Face acc. ASME B16.10
4. Dimension of connection end flange acc. ASME B16.5

### **DRW Industrietechnik GmbH**

Bodenschwinger Str. 125  
D-44357 Dortmund  
Telefon: +49 2 31 - 92 71 44-0  
info@drw-armaturen.de  
[www.drw-armaturen.de](http://www.drw-armaturen.de)



## Abmessungen / Dimensions:

SIZE	d	A	B	C	D	n	E	F
2"	50.8	267	23	165	127	8	19	92
2.5"	63.5	292	26	190	149.2	8	22	105
3"	76.2	318	29	210	168.5	8	22	127
4"	101.6	356	32	255	200	8	22	157
6"	152.4	444	37	320	270	12	22	216
8"	203.2	533	42	380	330	12	25	270
10"	254	622	48	445	387.5	16	29	324
12"	304.8	711	51	520	451	16	32	381
14"	336.6	838	54	585	514.5	20	32	413
16"	387.4	864	58	650	571.5	20	35	470
18"	431.8	978	61	710	628.5	24	35	533
20"	482.6	1016	64	775	686	24	35	584
24"	584.2	1346	70	915	813	24	41	692

## Materialien / Materials:

No.	Part Name	Material
1	Body	ASTM A351-CF8+STL
2	Disc	ASTM A182-F304
3	Arm	ASTM A351-CF8
4	Disc Washer	ASTM A276-304
5	Disc Nut	ASTM A276-304
6	Hinge Pin	ASTM A182-F304
7	Cover Gasket	SS316+Graphite
8	Cover	ASTM A351-CF8
9	Cover Studs	ASTM A193-B8
10	Cover Nuts	ASTM A194-8
11	Eye Bolt	ASTM A29-1035
12	Plug Gasket	SS304+Graphite
13	Plug	ASTM A276-304

### **DRW Industrietechnik GmbH**

Bodenschwinger Str. 125

D-44357 Dortmund

Telefon: +49 2 31 - 92 71 44-0

info@drw-armaturen.de

[www.drw-armaturen.de](http://www.drw-armaturen.de)

