

TYPE: DAS0129

Absperrschieber DN50- 500 PN10

Gate Valve DN50- 500 PN10

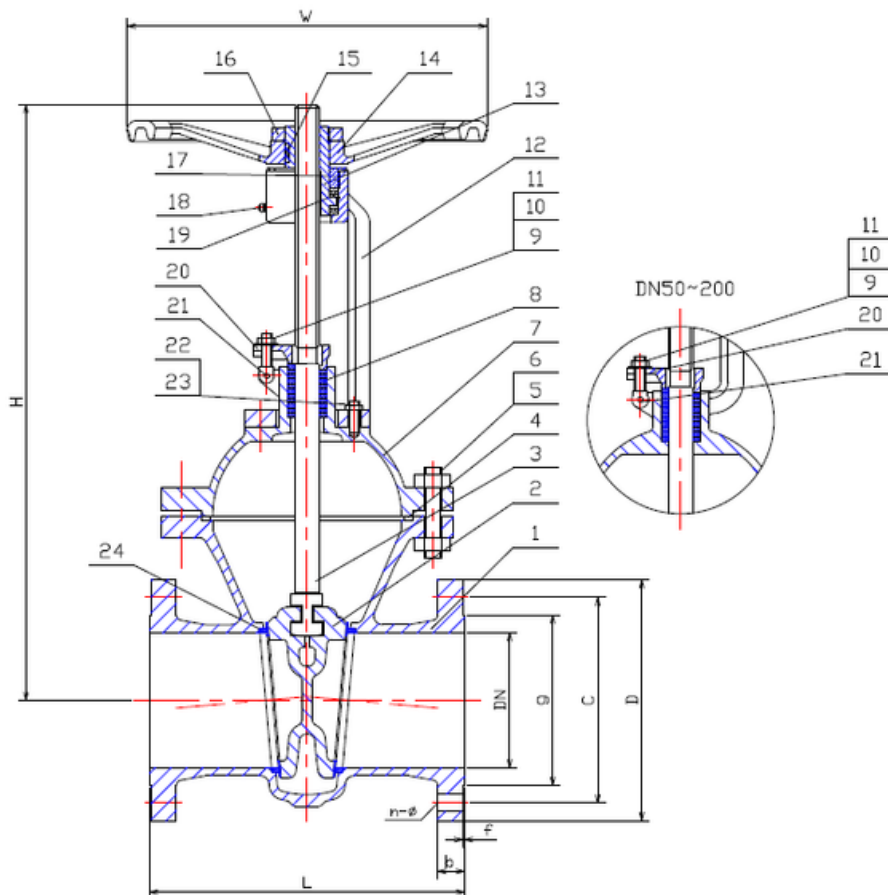

Technical Specification:

1. Design and machining in accordance with EN1984
2. Inspection and test in accordance with EN12266-1
3. Face to Face dimension in accordance with EN558-1 GR.15
4. Dimension of connection end flange in accordance with EN1092-1

DRW Industrietechnik GmbH

Bodenschwinger Str. 125

D-44357 Dortmund

Telefon: +49 2 31 - 92 71 44-0

info@drw-armaturen.de

www.drw-armaturen.de



Abmessungen / Dimensions:

DN	L	g	C	D	b	n-ø	f	W	H
50	250	102	125	165	20	4-18	3	200	325
65	270	122	145	185	18	4-18	3	225	365
80	280	138	160	200	20	4-18	3	225	405
100	300	158	180	220	20	8-18	3	250	475
125	325	188	210	250	22	8-18	3	360	560
150	350	212	240	285	22	8-23	3	400	645
200	400	268	295	340	24	8-23	3	400	800
250	450	320	350	395	26	12-23	3	450	945
300	500	370	400	445	28	12-23	4	500	1130
350	550	430	460	505	30	16-23	4	500	1260
400	600	482	515	565	32	16-27	4	600	1416
500	700	585	620	670	36	20-27	4	720	1760

Materialien / Materials:

No.	Part Name	Material
1	Body	LCB
2	Wedge Disc	LCB+13%Cr
3	Stem	13Cr
4	Gasket	SS304+Graphite
5	Studbolt	L7
6	Nut	7
7	Bonnet	LCB
8	Gland Packing	Graphite
9	Studbolt	L7
10	Nut	7
11	Washer	1.0402
12	Yoke	LCB
13	Yoke Sleeve	D2
14	Hand Wheel	GGG-40
15	Key	1.0503
16	Lock Nut	1.0501
17	Bonnet Nut	1.0501
18	Grease Nipple	1.0402
19	Roll Axletree	Axletree Steel
20	Gland Forging	LCB
21	Pin	1.0501
22	Studbolt	L7
23	Nut	7
24	Seat Ring	LF2+13%Cr

DRW Industrietechnik GmbH

Bodenschwinger Str. 125

D-44357 Dortmund

Telefon: +49 2 31 - 92 71 44-0

info@drw-armaturen.de

www.drw-armaturen.de

