

TYPE: DAS0302

Absperrschieber DN50- 600 PN25

Gate Valve DN50- 600 PN25

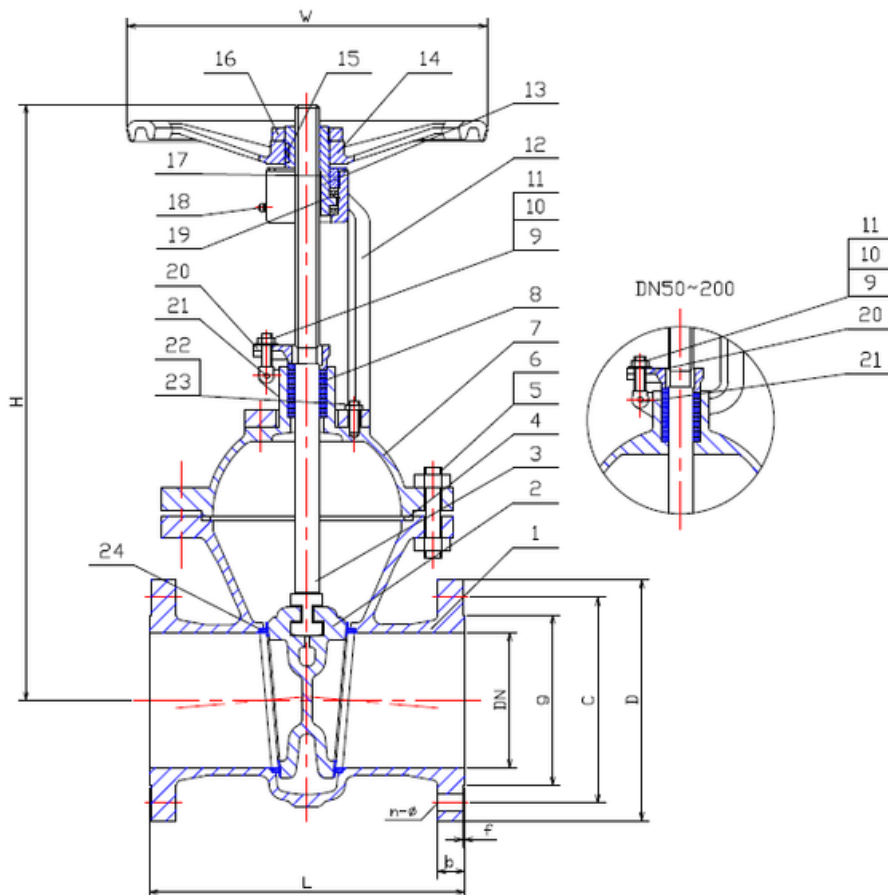

Technical Specification:

1. Design and machining in accordance with EN1984
2. Inspection and test in accordance with EN12266-1
3. Face to Face dimension in accordance with EN558-1 GR.15
4. Dimension of connection end flange in accordance with EN1092-1

DRW Industrietechnik GmbH

Bodenschwinger Str. 125

D-44357 Dortmund

Telefon: +49 2 31 - 92 71 44-0

info@drw-armaturen.de

www.drw-armaturen.de



Abmessungen / Dimensions:

DN	L	g	C	D	b	n-ø	f	W	H
50	250	102	125	165	20	4-18	3	200	325
65	270	122	145	185	22	8-18	3	225	365
80	280	138	160	200	24	8-18	3	225	405
100	300	162	190	235	24	8-22	3	250	475
125	325	188	220	270	26	8-26	3	360	560
150	350	218	250	300	28	8-26	3	400	645
200	400	278	310	360	30	12-26	3	400	800
250	450	335	370	425	32	12-30	3	450	945
300	500	395	430	485	34	16-30	4	500	1130
350	550	450	490	555	38	16-33	4	500	1260
400	600	505	550	620	40	16-36	4	600	1416
500	700	615	660	730	44	20-36	4	720	1760
600	800	720	770	845	46	20-39	5	750	2030

Materialien / Materials:

No.	Part Name	Material
1	Body	1.0619
2	Wedge Disc	1.0619+13%Cr
3	Stem	1.4006
4	Gasket	1.4301+Graphite
5	Studbolt	YK
6	Nut	YK
7	Bonnet	1.0619
8	Gland Packing	Graphite
9	Studbolt	YK
10	Nut	YK
11	Washer	1.0402
12	Yoke	1.0619
13	Yoke Sleeve	D2
14	Hand Wheel	GGG-40
15	Key	1.0503
16	Lock Nut	1.0501
17	Bonnet Nut	1.0501
18	Grease Nipple	1.0402
19	Roll Axletree	Axletree Steel
20	Gland Forging	1.0619
21	Pin	1.0501
22	Studbolt	YK
23	Nut	YK
24	Seat Ring	C22.8+13%Cr

DRW Industrietechnik GmbH

Bodenschwinger Str. 125

D-44357 Dortmund

Telefon: +49 2 31 - 92 71 44-0

info@drw-armaturen.de

www.drw-armaturen.de

