

## TYPE: DAS0509

DIN Absperrschieber DN50 – DN250 PN63

DIN Gate Valve DN50 – DN250 PN63

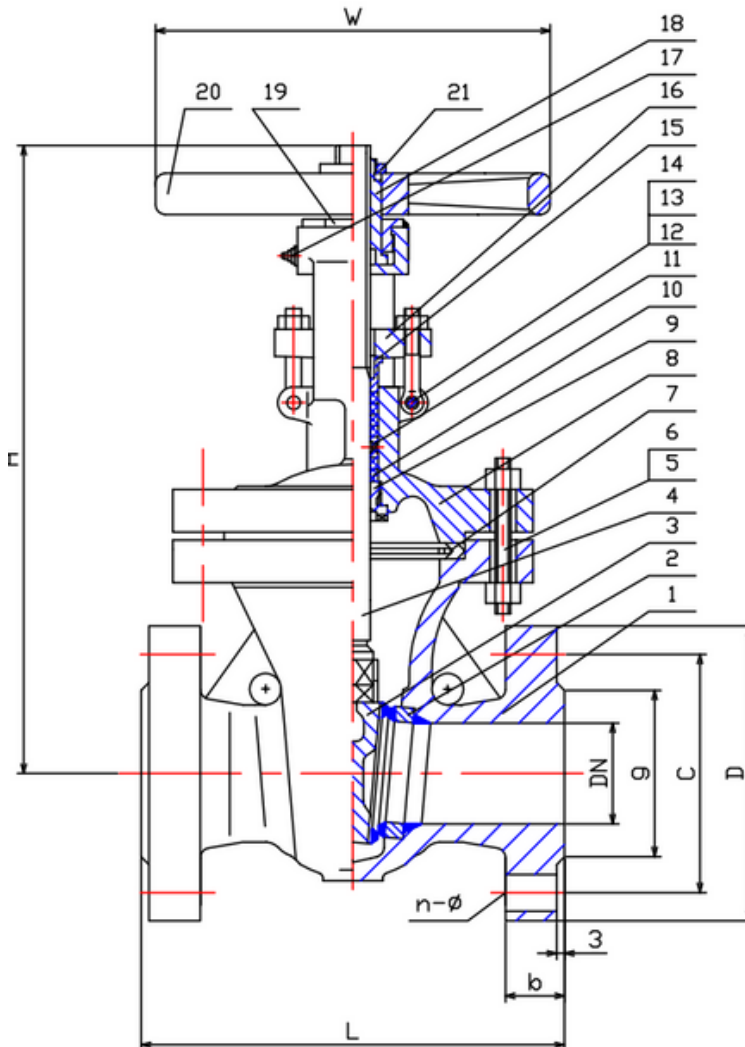

### Technical Specification:

1. Design and machining acc. with EN1984
2. Inspection and test acc. EN12266-1
3. Face to Face acc. EN 558 : Grundreihe 26
4. Dimension of connection end flange accordance with EN1092-1

### **DRW Industrietechnik GmbH**

Bodenschwinger Str. 125

D-44357 Dortmund

Telefon: +49 2 31 - 92 71 44-0

info@drw-armaturen.de

[www.drw-armaturen.de](http://www.drw-armaturen.de)



## Abmessungen / Dimensions:

DN	L	g	C	D	b	n-ø	H	W
50	250	102	135	180	26	4-22	360	200
65	290	122	160	205	26	8-22	405	250
80	310	138	170	215	28	8-22	450	250
100	350	162	200	250	30	8-26	530	300
125	400	188	240	295	34	8-30	630	350
150	450	218	280	345	63	8-33	710	400
200	550	285	345	415	42	12-36	810	500
250	650	345	400	470	46	12-36	950	500

## Materialien / Materials:

No.	Part Name	Material
1	Body	1.4408
2	Seat Ring	1.4401 + Stellite
3	Wedge Disc	1.4408
4	Stem	1.4401
5	Studbolt	A4
6	Nut	A4
7	Gasket	1.4401 + Graphite
8	Bonnet	1.4408
9	Backseat	1.4401
10	Gland Packing	Graphite
11	Jacket	1.4401
12	Studbolt	A4
13	Nut	A4
14	Pin	1.4401
15	Gland Follower	1.4401
16	Gland Flange	1.4408
17	Grease Nippel	1.0402
18	Yoke Sleeve	D2
19	Bonnet Nut	1.4006
20	Handwheel	GGG40
21	Lock Nut	1.4006

### **DRW Industrietechnik GmbH**

Bodenschwinger Str. 125

D-44357 Dortmund

Telefon: +49 2 31 - 92 71 44-0

info@drw-armaturen.de

[www.drw-armaturen.de](http://www.drw-armaturen.de)

