

## TYPE: DAS0602

DIN Absperrschieber DN50 – DN150 PN100

DIN Gate Valve DN50 – DN150 PN100

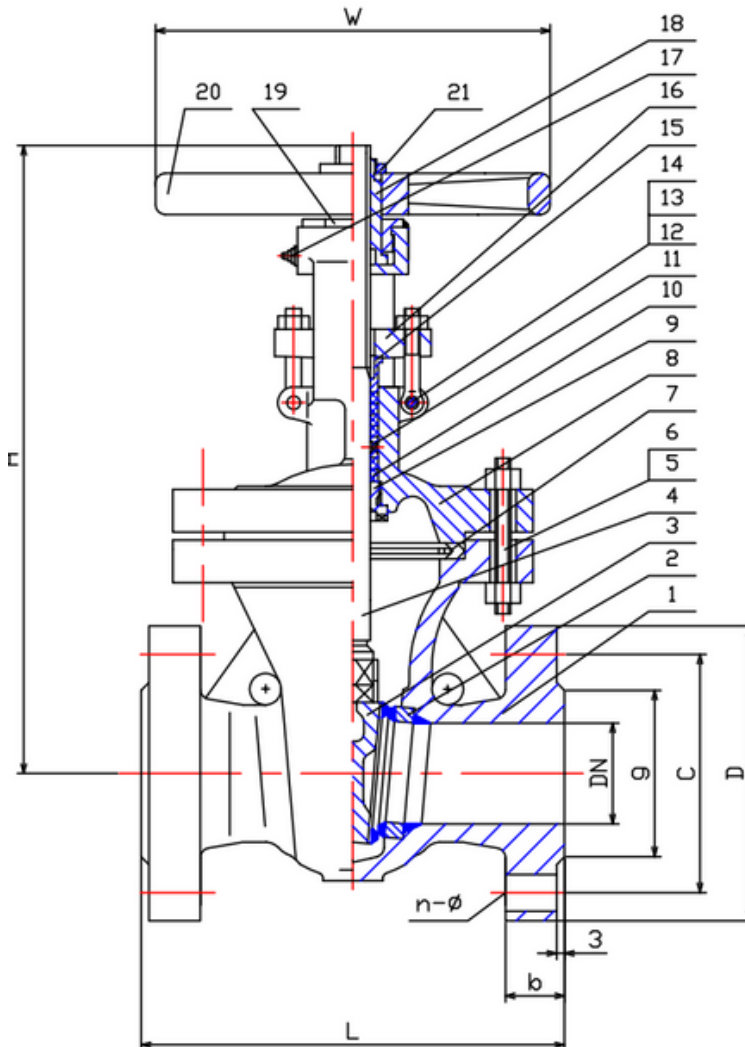

### Technical Specification:

1. Design and machining acc. with EN1984
2. Inspection and test acc. EN12266-1
3. Face to Face acc. EN 558 : Grundreihe 26
4. Dimension of connection end flange accordance with EN1092-1

### **DRW Industrietechnik GmbH**

Bodenschwinger Str. 125

D-44357 Dortmund

Telefon: +49 2 31 - 92 71 44-0

info@drw-armaturen.de

[www.drw-armaturen.de](http://www.drw-armaturen.de)



## Abmessungen / Dimensions:

DN	L	g	C	D	b	n-ø	F	W	H
50	250	102	145	195	8-26	30	3	450	380
65	290	122	170	220	8-26	34	3	400	425
80	310	138	180	230	8-26	36	3	350	470
100	350	162	210	265	8-30	40	3	300	560
125	400	188	250	315	8-33	40	3	250	605
150	450	218	290	355	12-33	44	3	250	650

## Materialien / Materials:

No.	Part Name	Material
1	Body	1.0619
2	Seat Ring	C22.8 + Stellite
3	Wedge Disc	1.0619 + 13 Cr
4	Stem	1.4006
5	Studbolt	YK
6	Nut	YK
7	Gasket	1.4301 + Graphite
8	Bonnet	1.0619
9	Backseat	1.4006
10	Gland Packing	Graphite
11	Jacket	1.4006
12	Studbolt	YK
13	Nut	YK
14	Pin	1.0501
15	Gland Follower	1.4006
16	Gland Flange	1.0619
17	Grease Nippel	1.0402
18	Yoke Sleeve	GGG-40
19	Bonnet Nut	1.0501
20	Handwheel	GGG-40
21	Lock Nut	1.0501

### **DRW Industrietechnik GmbH**

Bodenschwinger Str. 125

D-44357 Dortmund

Telefon: +49 2 31 - 92 71 44-0

info@drw-armaturen.de

[www.drw-armaturen.de](http://www.drw-armaturen.de)

