

TYPE: DRK0237

DIN Rückschlagklappe DN40 - DN400 PN16

DIN Swing Check Valve DN40 - DN400 PN16

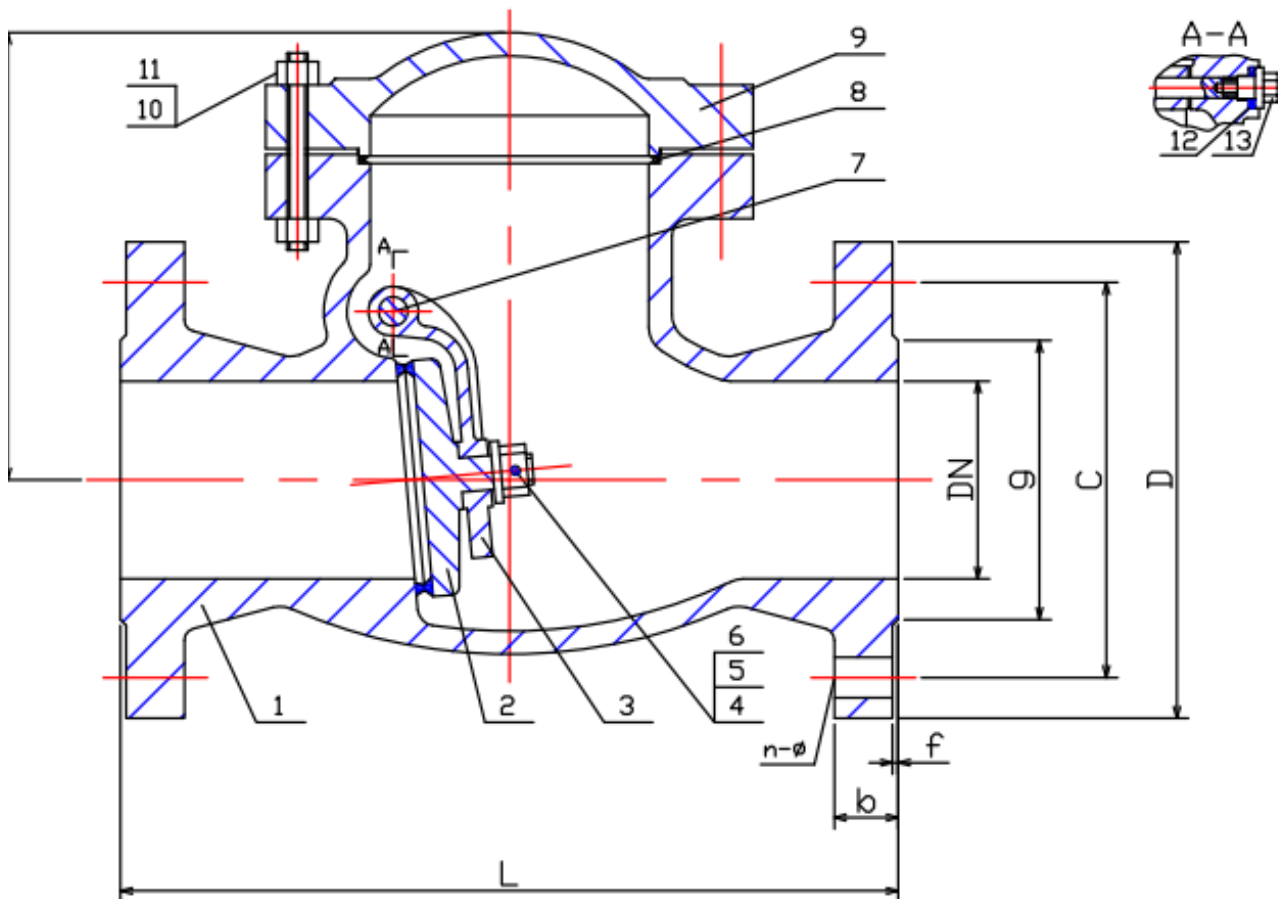

Technical Specification:

1. Design and machining acc. with EN14341
2. Inspection and test acc. EN12266-1
3. Face to Face acc. EN558-1 Gr.48
4. Dimension of connection end flange acc. EN1092-1 Type B

DRW Industrietechnik GmbH

Bodenschwinger Str. 125

D-44357 Dortmund

Telefon: +49 2 31 - 92 71 44-0

info@drw-armaturen.de

www.drw-armaturen.de



Abmessungen / Dimensions:

DN	L	g	C	D	b	f	n-ø	H
40	180	88	110	150	18	3	4-18	135
50	200	102	125	165	20	3	4-18	160
65	240	122	145	185	18	3	4-18	165
80	260	138	160	200	20	3	8-18	180
100	300	158	180	220	20	3	8-18	210
125	350	188	210	250	22	3	8-18	240
150	400	212	240	285	22	3	8-22	265
200	500	268	295	340	24	3	12-22	320
250	600	320	355	405	26	3	12-26	335
300	700	378	410	460	28	4	12-26	340
350	800	438	470	520	30	4	16-26	390
400	900	490	525	580	32	4	16-30	430

Materialien / Materials:

No.	Part Name	Material
1	Body	CF8M + STL
2	Disc	CF8M
3	Rocker	CF8M
4	Washer 1	F316
5	Nut	F316
6	Pin	SS316
7	Hing Pin	F316
8	Gasket	SS316 + Graphite
9	Bonnet	CF8M
10	Studbolt	B8M
11	Nut	8M
12	Washer 2	SS316
13	Plug Nut	F316

DRW Industrietechnik GmbH

Bodenschwinger Str. 125

D-44357 Dortmund

Telefon: +49 2 31 - 92 71 44-0

info@drw-armaturen.de

www.drw-armaturen.de

