

TYPE: DRK0209

Rückschlagklappe DN50 - DN400, PN16

Swing Check Valve DN50 - DN400, PN16

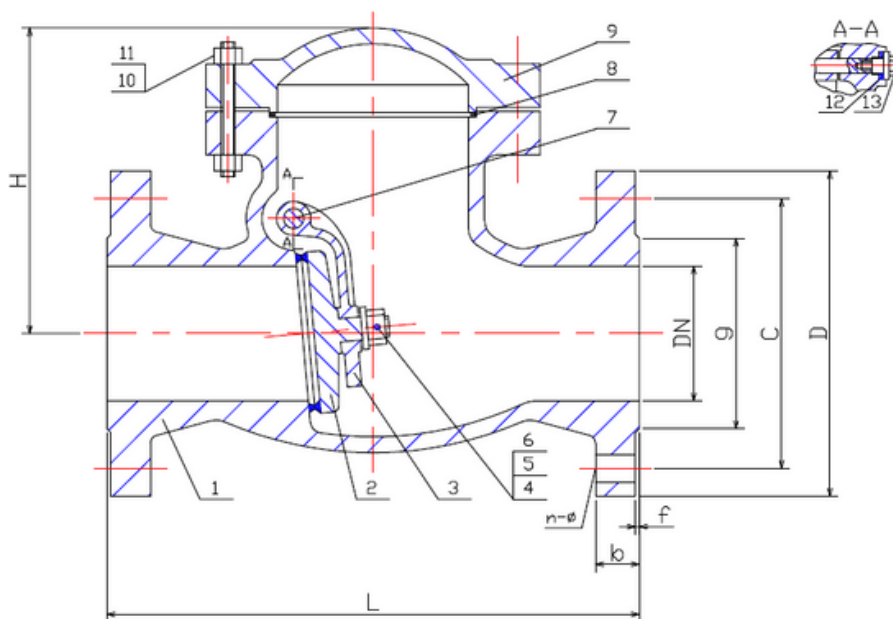

Technical Specification:

1. Design and machining in accordance with EN14341
2. Inspection and test in accordance with EN12266-1
3. Face to Face dimension in accordance with DIN3202-F6
4. Dimension of connection end accordance with EN1092-1

DRW Industrietechnik GmbH

Bodenschwinger Str. 125

D-44357 Dortmund

Telefon: +49 2 31 - 92 71 44-0

info@drw-armaturen.de

www.drw-armaturen.de



Abmessungen / Dimensions:

DN	L	g	C	D	b	n-ø	f	H
50	200	102	125	165	20	4-18	3	160
65	240	122	145	185	18	4-18	3	165
80	260	138	160	200	20	8-18	3	180
100	300	158	180	220	20	8-18	3	210
150	400	212	240	285	22	8-22	3	265
200	500	268	295	340	24	12-22	3	320
250	600	320	355	405	26	12-26	3	335
300	700	378	410	460	28	12-26	4	340
400	900	490	525	580	32	16-30	4	430

Materialien / Materials:

No.	Part Name	Material
1	Body	1.4408
2	Seat Ring	1.4401+STL
3	Disc	1.4408
4	Rocker	1.4408
5	Washer 1	1.4401
6	Nut	1.4401
7	Pin	1.4401
8	Hing Pin	1.4401
9	Gasket	1.4401+Graphite
10	Bonnet	1.4408
11	Studbolt	A4
12	Nut	A4
13	Washer 2	1.4404
14	Plug Nut	1.4401

DRW Industrietechnik GmbH

Bodenschwinger Str. 125

D-44357 Dortmund

Telefon: +49 2 31 - 92 71 44-0

info@drw-armaturen.de

www.drw-armaturen.de

