

TYPE: DRK0309

Rückschlagklappe DN40 - DN350, PN25

Swing Check Valve DN40 - DN350, PN25

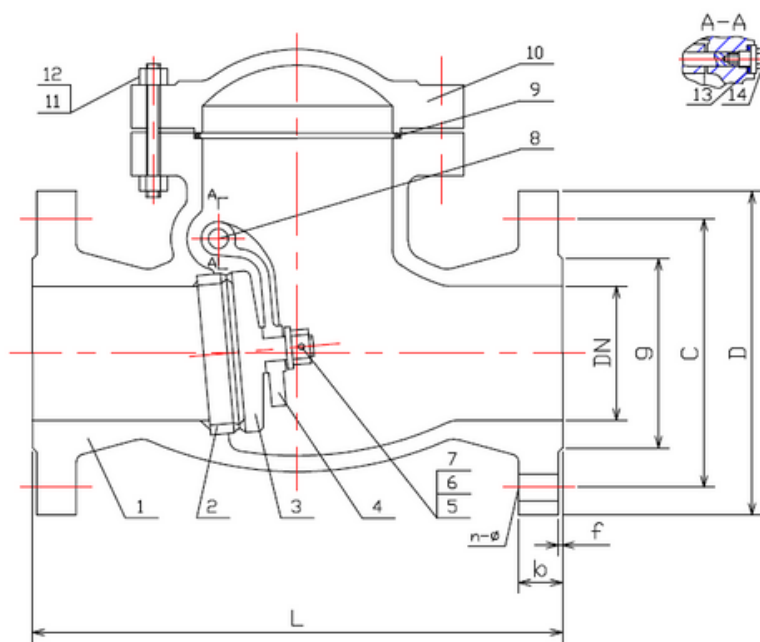

Technical Specification:

1. Design and machining in accordance with EN14341
2. Inspection and test in accordance with EN12266-1
3. Face to Face dimension in accordance with EN558-1 Gr.1
4. Dimension of connection end accordance with EN1092-1

DRW Industrietechnik GmbH

Bodenschwinger Str. 125

D-44357 Dortmund

Telefon: +49 2 31 - 92 71 44-0

info@drw-armaturen.de

www.drw-armaturen.de



Abmessungen / Dimensions:

| DN | L | g | C | D | b | n-ø | f |
|-----|-----|-----|-----|-----|----|-------|---|
| 40 | 200 | 88 | 110 | 150 | 18 | 4-18 | 3 |
| 50 | 230 | 102 | 125 | 165 | 20 | 4-18 | 3 |
| 65 | 290 | 122 | 145 | 185 | 22 | 8-18 | 3 |
| 80 | 310 | 138 | 160 | 200 | 24 | 8-18 | 3 |
| 100 | 350 | 162 | 190 | 235 | 24 | 8-22 | 3 |
| 125 | 400 | 188 | 220 | 270 | 26 | 8-26 | 3 |
| 150 | 480 | 218 | 250 | 300 | 28 | 8-26 | 3 |
| 200 | 600 | 278 | 310 | 360 | 30 | 12-26 | 3 |
| 250 | 730 | 335 | 370 | 425 | 32 | 12-30 | 3 |
| 300 | 850 | 395 | 430 | 485 | 34 | 16-30 | 4 |
| 350 | 980 | 450 | 490 | 555 | 38 | 16-33 | 4 |

Materialien / Materials:

| No. | Part Name | Material |
|-----|-----------|-----------------|
| 1 | Body | 1.4408 |
| 2 | Seat Ring | 1.4401+STL |
| 3 | Disc | 1.4408 |
| 4 | Rocker | 1.4408 |
| 5 | Washer 1 | 1.4401 |
| 6 | Nut | 1.4401 |
| 7 | Pin | 1.4401 |
| 8 | Hing Pin | 1.4401 |
| 9 | Gasket | 1.4401+Graphite |
| 10 | Bonnet | 1.4408 |
| 11 | Studbolt | A4 |
| 12 | Nut | A4 |
| 13 | Washer 2 | 1.4404 |
| 14 | Plug Nut | 1.4401 |

DRW Industrietechnik GmbH

Bodenschwinger Str. 125

D-44357 Dortmund

Telefon: +49 2 31 - 92 71 44-0

info@drw-armaturen.de

www.drw-armaturen.de

